

BOLT HIGH SPEED CINEBOT

The Fastest Robotic Arm in the World!



THE BOLT HIGH SPEED CINEBOT IS THE FASTEST OF ITS KIND - CAPTURING IMAGES IN CRISP FOCUS THAT WOULD BE IMPOSSIBLE BY HAND OR ANY OTHER METHOD. THE BOLT ADDS AN ENTIRELY NEW PERSPECTIVE TO FILMING - WHETHER SHOOTING COMMERCIALS, TABLETOP WORK, FILM OR TELEVISION.

Fastest Motion Control Arm in the World

Integrated Camera Cabling Through Arm

Camera Synchronisation for Frame Accurate Repeat Passes

Fastest & Most Powerful Zoom & Focus Motors

Flair Software: The industry standard, trusted by Operators & Production Companies worldwide

Moves 4.5m/s on Track



Bolt Specifications



TURNTABLES

Synchronised motion with external triggers and model movers for extreme precision timing.

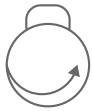

PORTABLE

Portable, lightweight robotic unit, designed to be set-up and ready for shooting in under an hour.



TIMECODE | LIGHTING

Trigger from timecode | Control DMX Lighting.



TIMELAPSE

Create incredible timelapse with dynamic movement and feel.



REPEATABLE

Every camera move under complete control - precisely repeatable.



TARGET TRACKING

Define location of your object in space, to simplify any complex move.



LENS CONTROL

High speed, precise control of zoom, iris & lens. Fastest & most powerful motors in the world.



MAYA

Take moves planned in Maya and feed them into the Bolt - or interface to augmented or virtual reality in real-time.

Operating Envelope	
Maximum Height	3.5m / 11'5"
Lowest position	0m / 0'
Maximum reach (from rotate centre)	2.0m / 6.6'

Rig Performance		
Axis	Range of Travel	Maximum Speeds
Rotate	+/- 160 degrees	240 degrees per second
Lift	+/- 137 degrees	240 degrees per second
Arm	+/- 150 degrees	300 degrees per second
Pan	+/- 270 degrees	315 degrees per second
Tilt	+/- 120 degrees /-105 degrees	350 degrees per second
Roll	+/-270 degrees	870 degrees per second
Track	Unlimited	4.5 metres per second

Practical Shooting Speeds	
Move	Speed
1m (3'3") vertical move	Half a second
1m (3'3") horizontal move	Half a second
Complete 180 degree arc with a 75cm (2'5") radius	1.5 seconds
Complete 180 degree arc with a 45cm (1'5") radius	1 second

Rig Weights		
	Kg	Lbs
Bolt Rig	600	1323
Maximum camera payload	20	44

Note: counter weights may be required depending on the shot and length of track

Power Connection	
Power requirements	3x 400 volts, 32 amps, 50-60 Hz
Generator	3k VA (Bolt) 14K VA (Bolt on Track)

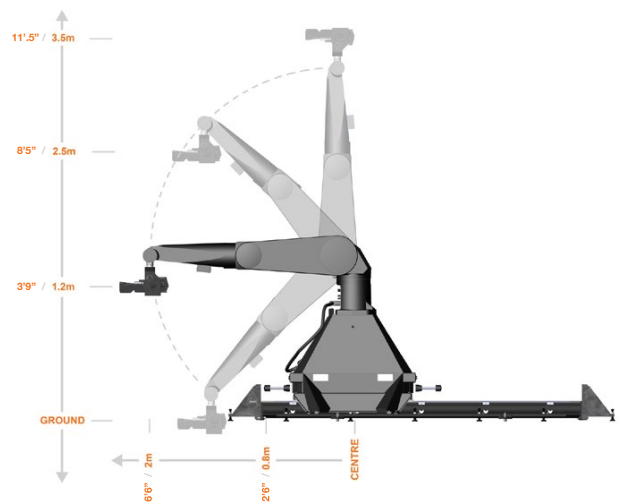

Unparalleled 24/7 Technical Support

Mark Roberts Motion Control
 Tel: +44 (0)1342 838000
 Email: info@mrmoco.com
 www.mrmoco.com/bolt